



ENGINE

Model	Kubota D1305
Emissions Certification	Tier 4 Final
Fuel	Diesel
Cylinders	3
Displacement	77.0 in ³ (1 261 cc)
Fuel injection	Mechanical
Gross horsepower – SAE J1995 @ 2300 RPM:	24.8 hp (18.5 kW)
Net horsepower – SAE J1349 @ 2300 RPM:	23.2 hp (17.3 kW)
Maximum Engine Torque @ 1600 RPM:	60.0 lb ft (81.4 Nm)
Cooling	Water-cooled

DRIVETRAIN

Travel speeds:	
1st	1.5 mph (2.4 kph)
2nd	2.7 mph (4.3 kph)
Maximum traction force	4,800 lb (2 177 kg)
Gradeability	30° (58%)
Ground pressure:	
Canopy	3.8 psi (0.27 kgf/cm ²)
Cab	4.1 psi (0.29 kgf/cm ²)

ELECTRICAL

Voltage	12 Volts
Alternator rating	40 amp
Battery	1 x 12 V x 80 Ah 630 CCA

OPERATOR ENVIRONMENT

ROPS/FOPS four post canopy; ISO 6396: 2008 sound pressure level LpA=73.5dB (A); Pilot operated hand controls and foot pedals; Adjustable seat w/seat belt; Arm rests; 12V socket.

Display includes:

Engine oil pressure lamp; Water temperature lamp; Low fuel warning lamp; Battery charge lamp; Engine preheat lamp; Travel speed lamp; Air cleaner warning lamp; Hyd. quick coupler lock lamp; High travel speed lamp; Water temperature gauge; Fuel gauge and Hour meter.

OPERATING WEIGHT

Canopy operating weight	6,306 lb (2 860 kg)
Cab operating weight	6,636 lb (3 010 kg)

NOTE: w/rubber tracks/no quick coupler/bucket/fluids/full of fuel/165 lb operator.

HYDRAULICS

Main pumps:	Variable displacement tandem axial piston pump
Max rated flow x 2:	7.3 gpm (27.6 L/min)

Auxiliary flow @ 2,538 psi (175 bar):	
Primary	12.5 gpm (47.2 L/min)
Secondary	12.5 gpm (47.2 L/min)

System relief pressure:	
Standard	3,130 psi (220 bar)
Overload relief valve	3,410 psi (240 bar)

Pilot control hydraulic system:	
Pump	Gear Pump
Maximum capacity	2.7 gpm (10.4 L/min)

Control valves:	
Pilot control for left/right track travel, boom, arm, bucket and swing	
Manual control for breaker and backfill blade	

Swing motor:	Fixed displacement axial piston motor
--------------	---------------------------------------

Travel motor:	Variable displacement axial piston 2-stage planetary Automatic spring applied hydraulic released brake
---------------	---

SERVICE CAPACITIES

Fuel tank	7.9 gal (30 L)
Hydraulic tank:	
Refill capacity	7.1 gal (27 L)
Total system	14.5 gal (55 L)
Engine oil w/filter change	1.6 gal (5.9 L)
Radiator	1.3 gal (5 L)

OTHER SPECIFICATIONS

Swing speed	0 – 9.1 RPM
Undercarriage:	
Track rollers	1 upper/4 lower each
Boom:	
Swing	75° left/50° right
Length	6 ft 8 in (2.03 m)
Arm:	
Standard length	3 ft 8 in (1.12 m)

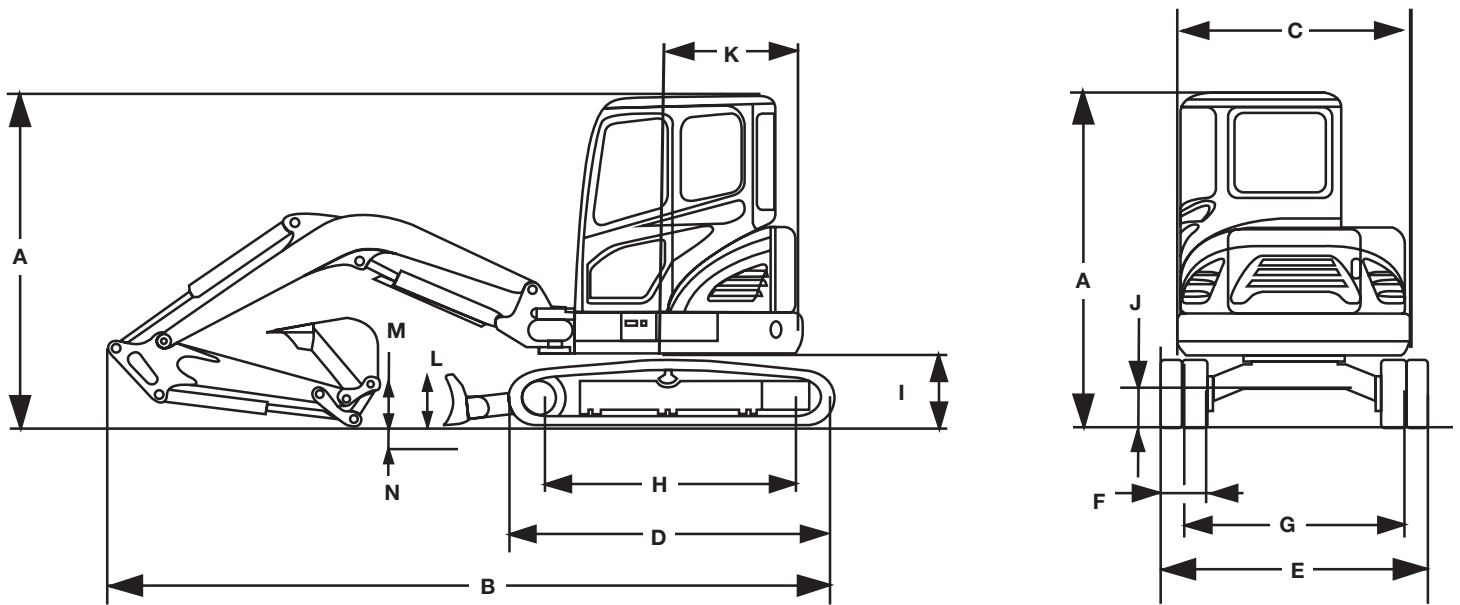

Line drawings are for illustrative purpose only and may not be exact representation of unit.

DIMENSIONS

3 ft 8 in (1.12 m) Arm

A. Overall height	8 ft 2 in (2 500 mm)
B. Overall transport length	13 ft 9 in (4 180 mm)
C. Width of upper structure	4 ft 10 in (1 485 mm)
D. Track overall length	6 ft 6 in (1 970 mm)
E. Track overall width	5 ft 1 in (1 550 mm)
F. Track shoe width	11.8 in (300 mm)
G. Track gauge	4 ft 1 in (1 250 mm)
H. Center to center - idler to sprocket	4 ft 11 in (1 490 mm)
I. Upper structure ground clearance	1 ft 8 in (510 mm)
J. Minimum ground clearance	11 in (290 mm)
K. Tail swing radius:	
Standard counterweight	2 ft 6 in (750 mm)
Additional counterweight	2 ft 10 in (875 mm)
Boom swing	75° left/50° right
Tail swing overhang:	
Standard counterweight	0 in (0 mm)
Additional counterweight	5 in (125 mm)

BLADE SPECS

L. Backfill blade height	1 ft 1 in (330 mm)
M. Backfill blade rise above ground	1 ft 7 in (370 mm)
N. Backfill blade dig depth	1 ft 6 in (450 mm)
Backfill blade width	5 ft 1 in (1 550 mm)

PERFORMANCE SPECS

3 ft 8 in (1.12 m) Arm

O. Maximum dig radius	15 ft 3 in (4 650 mm)
P. Dig radius at groundline	14 ft 10 in (4 515 mm)
Q. Maximum dig depth	8 ft 2 in (2 500 mm)
R. Vertical straight wall dig depth	6 ft 10 in (2 085 mm)
S. Dump height	9 ft 7 in (2 930 mm)
T. Overall reach height	14 ft 0 in (4 270 mm)
U. Bucket rotation	177°
Arm digging force - ISO	3,080 lbf (1 397 kgf/13.7 kN)
Bucket digging force - ISO	4,520 lbf (2 050 kgf/20.1 kN)

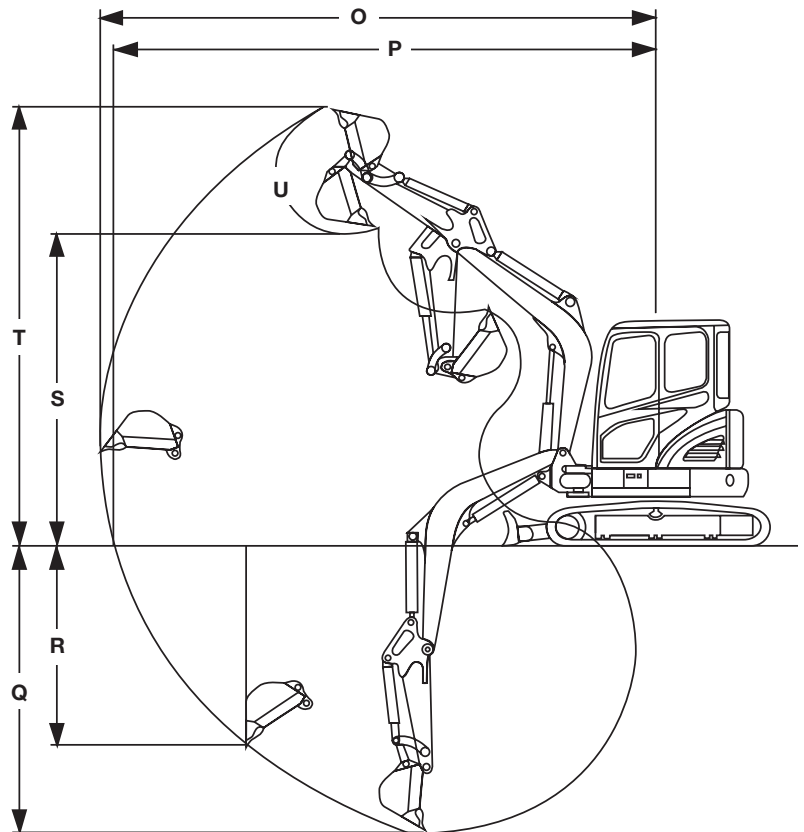

LIFT CAPACITIES

6 ft 8 in (2.03 m) Boom, 3 ft 8 in (1.12 m) Arm, Dozer Blade Down Canopy unit equipped with 0.08 m³ (SAE heaped) bucket, 10 in (250 mm) rubber track and 772 lb (350 kg) counterweight.

Load / Lift Point Height	LOAD RADIUS										MAXIMUM REACH		
	7 ft (2.0 m)		8 ft (2.5 m)		10 ft (3.0 m)		12 ft (3.5 m)		13 ft (4.0 m)		REACH	CAPACITY	
	END	SIDE	END	SIDE	END	SIDE	END	SIDE	END	SIDE	@	END	SIDE
+12 ft (3.5 m)											8 ft 11 in (2.73 m)	1,200 lb* (550 kg)*	1,200 lb* (550 kg)*
+10 ft (3.0 m)					1,270 lb* (580 kg)*	1,080 lb (490 kg)					10 ft 9 in (3.27 m)	1,070 lb* (490 kg)*	920 lb (420 kg)
+8 ft (2.5 m)					1,300 lb* (590 kg)*	1,070 lb (490 kg)	1,360 lb* (610 kg)*	810 lb (370 kg)			11 ft 11 in (3.62 m)	1,030 lb* (470 kg)*	760 lb (350 kg)
+7 ft (2.0 m)					1,460 lb* (660 kg)*	1,050 lb (480 kg)	1,410 lb* (640 kg)*	800 lb (360 kg)			12 ft 7 in (3.84 m)	1,030 lb* (470 kg)*	680 lb (310 kg)
+5 ft (1.5 m)	2,840 lb* (1 290 kg)*	1,970 lb (890 kg)	2,060 lb* (930 kg)*	1,370 lb (620 kg)	1,720 lb* (780 kg)*	1,010 lb (460 kg)	1,540 lb* (700 kg)*	780 lb (350 kg)			13 ft 0 in (3.96 m)	1,060 lb* (480 kg)*	630 lb (280 kg)
+3 ft (1.0 m)	4,070 lb* (1 850 kg)*	1,830 lb (830 kg)	2,600 lb* (1 180 kg)*	1,300 lb (590 kg)	2,000 lb* (910 kg)*	970 lb (440 kg)	1,690 lb* (770 kg)*	760 lb (340 kg)	1,170 lb* (530 kg)*	610 lb (270 kg)	13 ft 2 in (4.01 m)	1,140 lb* (520 kg)*	600 lb (270 kg)
+2 ft (0.5 m)	3,270 lb* (1 480 kg)*	1,750 lb (790 kg)	3,000 lb* (1 360 kg)*	1,240 lb (560 kg)	2,240 lb* (1 020 kg)*	940 lb (430 kg)	1,820 lb* (830 kg)*	740 lb (340 kg)			13 ft 0 in (3.97 m)	1,260 lb* (570 kg)*	600 lb (270 kg)
Groundline	3,820 lb* (1 730 kg)*	1,730 lb (780 kg)	3,170 lb* (1 440 kg)*	1,210 lb (550 kg)	2,370 lb* (1 070 kg)*	920 lb (420 kg)	1,890 lb* (860 kg)*	730 lb (330 kg)			12 ft 7 in (3.84 m)	1,460 lb* (660 kg)*	630 lb (280 kg)
-2 ft (-0.5 m)	4,470 lb* (2 030 kg)*	1,730 lb (780 kg)	3,130 lb* (1 420 kg)*	1,200 lb (550 kg)	2,350 lb* (1 070 kg)*	910 lb (410 kg)	1,840 lb* (830 kg)*	720 lb (330 kg)			11 ft 11 in (3.62 m)	1,720 lb* (780 kg)*	690 lb (310 kg)
-3 ft (-1.0 m)	4,000 lb* (1 810 kg)*	1,740 lb (790 kg)	2,870 lb* (1 300 kg)*	1,210 lb (550 kg)	2,150 lb* (980 kg)*	910 lb (410 kg)					10 ft 9 in (3.28 m)	1,810 lb* (820 kg)*	800 lb (360 kg)
-5 ft (-1.5 m)	3,160 lb* (1 430 kg)*	1,780 lb (810 kg)	2,270 lb* (1 030 kg)*	1,240 lb (560 kg)							9 ft 0 in (2.75 m)	1,900 lb* (860 kg)*	1,070 lb (480 kg)

NOTE: Lifting capacity are based on ISO 10567.

Lifting capacity does not exceed 75% of tipping load with the machine on firm, level ground or 87% of full hydraulic capacity.

The lift point is a hook located on the back of the bucket.

*Indicates load limited by hydraulic capacity.

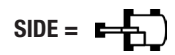
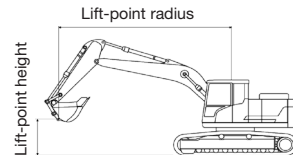

STANDARD EQUIPMENT

ENGINE

Kubota D1305 diesel
Engine access under rear hood
Glow plug starting aid
Dry type air cleaner with restriction indicator

ELECTRICAL

12-volt electrical starting system
Heavy-duty battery
Battery Master Switch
Key Start
Anti-Theft-Engine starting passwords
Front working light
12 V power outlet
Horn
Pre-wired – Telematics ready

HYDRAULICS

Auxiliary hydraulics – single/bi-directional –
and plumbing to arm
Large hydraulic oil cooler
Control pattern selector valve
Cylinder rod protection covers – Dozer, Boom

TRACK DRIVE

Rubber belt tracks
Automatic 2-speed travel
Fully hydrostatic drive system
Sealed and lubricated track rollers
Track tension adjustment – grease type

UPPER STRUCTURE

Zero tail swing
Standard arm: 3 ft 8 in (1.12 m)
Bucket linkage with lifting hook

OPERATOR ENVIRONMENT

See page 1

OTHER

Swing boom – 75° left/50° right
Hydraulic backfill blade
Additional counterweight adds 286 lb (130 kg)

WARRANTY

Base warranty coverage: 2-Year/3,000-Hour
Full Machine Limited Warranty

OPTIONAL EQUIPMENT

OPERATOR ENVIRONMENT

Cab with Heat and Radio with USB
and 2 speakers
Travel alarm

OTHER

Thumb bracket
Hydraulic quick coupler provision
Hydraulic coupler
Klacc coupler
Mechanical coupler
Hydraulic hammer
Beacon
2nd auxiliary circuit
Hydraulic thumb

CaseCE.com

©2017 CNH Industrial America LLC. All rights reserved. CASE is a trademark registered in the United States and many other countries, owned by or licensed to CNH Industrial N.V., its subsidiaries or affiliates. CNH Industrial Capital is a trademark in the United States and many other countries, owned by or licensed to CNH Industrial N.V., its subsidiaries or affiliates. Printed in U.S.A. Contains 10% post-consumer fiber.

IMPORTANT: CASE Construction Equipment Inc. reserves the right to change these specifications without notice and without incurring any obligation relating to such change. Availability of some models and equipment builds vary according to the country in which the equipment is used. The illustrations and text may include optional equipment and accessories and may not include all standard equipment. Your CASE dealer/distributor will be able to give you details of the products and their specifications available in your area.



CASE Construction Equipment is biodiesel-friendly. NOTE: All engines meet current EPA emissions regulations. All specifications are stated in accordance with SAE Standards or Recommended Practices, where applicable.



Always read the Operator's Manual before operating any equipment. Inspect equipment before using it, and be sure it is operating properly. Follow the product safety signs and use any safety features provided.

Form No. CCE201711CX30C
Replaces Form No. CCE201710CX30C

CX30C

4 of 4